

DOCUMENT 00 11 13 - ADVERTISEMENT FOR BIDS

1.1 PROJECT INFORMATION

- A. Notice to Bidders: Qualified bidders may submit bids for project as described in this Document. Submit bids according to the Instructions to Bidders.
- B. Project Identification: MTD Lift Replacement.
  - 1. Project Location: 803 E. University Ave., Urbana, IL, 61802.
- C. Owner: Champaign-Urbana Mass Transit District (MTD).
- D. Architect: IGW Architecture (Isaksen Glerum Wachter LLC), 114 West Main Street, Urbana IL 61801, Telephone No. (217) 328-1391.

Project Description: The project consists of removing and disposing two (2) existing lifts at two bays of the MTD Maintenance Facility. Furnishing and installing two (2) new lifts in those two bays in the existing MTD bus maintenance facility including associated concrete and electrical work. Two additional lifts are bid as alternate bids.

- E. Construction Contract: Bids will be received for the following Work:
  - 1. General Contract (all trades).
  - 2. **Any contract resulting from these bids is subject to financial assistance contracts between CU-MTD and the United States Department of Transportation and the Illinois Department of Transportation.**
  - 3. **Contractor will be required to comply with all applicable Equal Employment Opportunity laws and regulations.**
  - 4. **The construction work for this project is subject to the Federal Davis-Bacon Prevailing Wage Act, in the matter of prevailing wages.** As such, the general prevailing rate of wages in the locality for each craft or type of worker or mechanic needed to execute the contract or perform such work, also the general prevailing rate for legal holiday and overtime work, as ascertained by **the United States Department of Labor**, shall be paid for each craft or type of worker needed to execute the contract or to perform such work. Accurate payroll records shall be kept by the Contractor and each subcontractor, and shall be submitted with each pay request
  - 5. The District also hereby notifies bidders that they affirmatively ensure that all Disadvantaged Business Enterprises, as defined by the United States Government, are afforded full opportunity to submit proposals in response to this invitation and will not knowingly discriminate against any bidder upon the grounds of gender, race, color or national origin in the consideration of award of the contract. The contractor will be required to comply with all applicable Federal and State Equal Opportunity laws and regulations. The DBE goal for this project is 5.45%. The DBE Directory can be found at the Illinois Unified Certification Program (UCP) website: <http://www.idot.illinois.gov/doing-business/certifications/disadvantaged-business-enterprise-certification/il-ucp-directory/index>

6. The District will be bound by the terms and conditions of the bid only to the extent funds from whatever source are available.

## 1.2 BID SUBMITTAL AND OPENING

- A. MTD, Urbana, Illinois will receive sealed lump sum bids until the bid time and date at the location given below. Owner will consider bids prepared in compliance with the Instructions to Bidders issued by Owner, and delivered as follows:
  1. Pre-Bid Date: 09 July 2019
  2. Pre-Bid Time: 1:30 p.m. CST, local time.
  3. Location: MTD Maintenance Facility, 803 E. University Ave., Urbana, IL, 61802.
  4. Bid Date: 16 July 2019
  5. Bid Time: 1:30 p.m. CST, local time.
  6. Location: MTD Headquarters, 1101 E. University Ave., Urbana, IL, 61802.
- B. Bids will be thereafter publicly opened and read aloud.
- C. The right is reserved to accept any bid or any part or parts thereof or to reject any and all bids. The District, with concurrence of the Illinois Department of Transportation (IDOT), will award the bid to the most qualified, responsive and responsible bidder that submits the lowest priced bid based on the base bid plus any accepted alternates. After selection, the owner reserves the right to exercise the alternate. Acceptance of any bid is subject to concurrence by IDOT (and the US DOT).

## 1.3 BID SECURITY

- A. A bid bond, bank draft, or certified check made payable to the MTD Board, Urbana, Illinois, in the amount of ten percent of the Base Bid proposal shall accompany each bid as a guarantee that the Bidder, if awarded the Contract, will furnish satisfactory Performance Bond, Labor and Material Payment Bond, in the amount of 100% of the contract sum, execute the Contract and proceed with the Work. Upon failure to do so, he/she shall forfeit the deposit or amount of bid bond as liquidated damages, and no mistakes or errors on the part of the Bidder will excuse the Bidder or entitle him/her to a return of the deposit or bid bond. No Bidder may withdraw his/her bid for a period of 120 days after the date of opening thereof. The bid bonds or checks will, with the exception of those of the three lowest bidders, be returned seven days after the opening of bids and the remaining checks or bid bonds will be returned when the Contract is executed and bond provided.
- B. The successful bidders will be required to furnish a Performance Bond and Labor and Material Payment Bond in form and Surety as specified and in the full amount of the contracts. Cost of such bonds shall be included in the Bidder's Proposal.

## 1.4 SITE VISIT

- A. Bidders are asked to contact owner to visit the site.

## 1.5 DOCUMENTS

- A. Procurement and Contracting Documents will be available after June 17, 2019 by contacting Sharada Panditi at [spanditi@igwarchitecture.com](mailto:spanditi@igwarchitecture.com).

- B. Viewing Procurement and Contracting Documents: Examine after June 17, 2019, at the locations below:
  - 1. IGW Architecture: 114 West Main Street, Urbana, IL 61801.
  - 2. MTD Administration Office: 1101 E. University Ave, Urbana, Illinois 618

1.6 TIME OF COMPLETION

- A. Successful bidder shall begin the Work on receipt of the Notice to Proceed and shall complete the Work within the Contract Time as stated on the Bid Proposal.

1.7 BIDDER'S QUALIFICATIONS

- A. Bidders must be properly licensed under the laws governing their respective trades and be able to obtain insurance and bonds required for the Work.
- B. The successful bidders will be required to furnish a Performance Bond, separate Labor and Material Payment Bond, and Insurance in form and Surety as specified and in the full amount of the contracts. Cost of such bonds shall be included in the Bidder's Proposal.

1.8 NOTIFICATION

- A. This Advertisement for Bids document is issued by the Champaign-Urbana Mass Transit District.

END OF DOCUMENT 00 11 13

**BIDDING & CONTRACT REQUIREMENTS**

Document 009001 – Addendum No. 01

DATE: July 11, 2019

The MTD Board  
1101 E. University Ave  
Urbana, Illinois 61802

IGW Architecture  
114 West Main Street / Urbana, Illinois 61801  
Tel 217-328-1391 Fax 217-328-1401

TO: PROSPECTIVE BIDDERS

SUBJECT: ADDENDUM NO. 1 TO THE BIDDING DOCUMENTS FOR

CUMTD – Lift Replacement  
803 E. University Ave., Urbana, IL, 61802

This addendum forms a part of the bidding and contract documents and modifies the original bidding documents, dated June 17, 2019. Acknowledge receipt of this addendum in space provided on Bid Form. FAILURE TO DO SO MAY SUBJECT BIDDER TO DISQUALIFICATION.

1. See attached pre-bid agenda with notes and attached important DBE information, sign-in sheet and existing lift drawing information.

**PROJECT MANUAL**

None.

**DRAWINGS:**

None.

Bids are due on **Tuesday, July 16, 2019** at 1:30 P.M. prevailing time.

Bids are due at: CUMTD-Headquarters,  
1101 E. University Ave  
Urbana, IL, 61802

Attachments:

Pre-bid Agenda with notes DBE information; Sign-in -sheet and Existing Lift drawing information.  
Specification Sections: None  
Drawings: None

Respectfully submitted,  
IGW Architecture

This addendum consists of 1 pages.

File: 1825

## PRE-BID CONFERENCE AGENDA

PROJECT: CUMTD – Lift Replacement

MEETING DATE/TIME: 09 July 2019 / 1:30 PM

MEETING LOCATION: CU-MTD – 803 East University, Urbana, IL- 61802

### A. Introductions:

1. Owner: Jane Sullivan, Eric Broga, Kirk Kirkland (CU-MTD)
2. Architect: Scot Wachter, Sharada Panditi (IGW)

### C. Project Overview / Description of Work

1. Project bid and constructed under single General Contract.
2. Project Scope
3. See attached DBE information **DBE information with example sheets**
4. Exhibit I-1 - Vendor Checklist
5. Form 2025 – DBE Participation – Goal of 5.45%
6. Form 2065 – DBE Utilization - DBE Directory can be found at the Illinois Unified Certification Program website: <http://www.idot.illinois.gov/doing-business/certifications/disadvantaged-business-enterprise-certification/il-ucp-directory/index>
7. Form 10c – Evidence of Good Faith Efforts Checklist
8. Prevailing wage is required
9. CU-MTD is sales tax exempt
10. 10% Bid Bond required
11. Performance and payment bonds required

### D. Project Schedule:

1. Receipt of Bids – July 16, 2019
2. Contract sent to IDOT for approval and anticipated Notice of Award after Board approval – July 31, 2019
3. Start of Construction – After August 1st, 2019 - TBD
4. Substantial Completion – March 02, 2020
5. Final Completion – March 09, 2020
6. Post Construction (Warranty) – March 02, 2020 thru March 02, 2020

### E. Special Project Considerations:

1. Complete lift system including electrical.

### F. Addenda

1. Addenda items

1. See attached Sign-in sheet.
2. Existing Lift Information drawings to be included in Addendum#1.

### G. Comments / Questions

Champaign-Urbana Mass Transit District  
Vehicle Lift Replacement Project

**Disadvantaged Business Enterprise Contract Goal: 5.45%**

The Champaign-Urbana Mass Transit District (MTD) has an established Disadvantaged Business Enterprise Program (DBE) in accordance with the U.S. Department of Transportation 49 CFR Part 26. It is the policy of the MTD to ensure that DBEs are afforded full opportunity to submit proposals in response to this invitation.

Instructions to bidders:

- 1) The DBE Participation Statement (Form 2025) and DBE Utilization Plan (Form 2026) must be submitted with all proposal documents at the time of submittal.
- 2) Only businesses listed in the Illinois Unified Certification Program Directory at the time of submittal will be counted towards fulfillment of the DBE goal. <http://www.idot.illinois.gov/doing-business/certifications/disadvantaged-business-enterprise-certification/il-ucp-directory/index>.
- 3) You may only count expenditures to a DBE contractor toward if the DBE is performing a commercially useful function on that contract.
  - a. If the materials or supplies are purchased from a DBE regular dealer, you may only count **60 percent** of the cost of the materials or supplies toward DBE goal.
  - b. If the materials or supplies are obtained from a DBE manufacturer, count **100 percent** of the cost of the materials or supplies toward DBE goals.
- 4) Areas for subcontracting opportunities on this contract might include:
  - a. Electrical Contractors and Other Wiring Installation Contractors
    - i. NAICS 238210
    - ii. 68 DBEs available in Illinois
  - b. Poured Concrete Foundation and Structure Contractors
    - i. NAICS 238110
    - ii. 157 DBEs available in Illinois
  - c. Site Preparation Contractors
    - i. NAICS 238910
    - ii. 103 DBEs available in Illinois
  - d. Freight Transportation Arrangement
    - i. NAICS 488510
    - ii. 2 DBEs available in Illinois
- 5) If 5.45% of your cost proposal will not be completed by an IDOT UCP certified business, documented evidence of adequate good faith efforts to obtain participation by certified DBEs on this contract must be submitted with your proposal. Refer to [49 CFR Part 26 Subpart C 26.53](#). Examples include:
  - a. Phone logs of contact made to IDOT UCP certified DBEs
  - b. Email correspondence/efforts

- c. Copies of each DBE and non-DBE subcontractor quote submitted to the proposer when a non-DBE subcontractor was selected over a DBE for work on the contract to review. DBE prices must be substantially higher in order for this to be accepted as good faith effort.

If you are a DBE or small business interested in participating on this project and need assistance connecting with a potential prime contractor, please contact Jane Sullivan [jsullivan@mtd.org](mailto:jsullivan@mtd.org) (217.384.8188).

For general information on MTD's DBE program, contact MTD's DBE Liaison Officer:

Brenda Eilbracht

1101 E University Ave. Urbana, IL 61802

[beilbracht@mtd.org](mailto:beilbracht@mtd.org)

217.384.8188

# EXAMPLE OF COMPLETED FORM

## DBE Participation Statement

<b>Prime Contractor:</b> <span style="color: red;">Company A</span>	<b>Bid Date:</b> <span style="color: red;">07/16/2019</span>
<b>Job Location:</b>	<small>Street</small> Champaign-Urbana MTD    803 E University Ave.
	<small>City</small> Urbana
	<small>County</small> Champaign
<b>Job Description:</b>	Vehicle Lift Replacement

### 1. Instructions

This form must be completed for each disadvantaged business participating in the Utilization Plan. This form shall be submitted in accordance with the special provision and will be attached to the Utilization Plan form. If additional space is needed, complete an additional form for the firm.

### 2. Work

Item	Description of Work	Quantity	Unit Price	Total
	Site Preparation	N/A		\$4.00
<b>Total</b>				<b>\$4.00</b>

### 3. Partial Payment Items

For any of the above items which are partial pay items, specifically describe the work and subcontract dollar amount below.

### 4. Commitment

The undersigned certify that the information included herein is true and correct, and that the DBE firm listed below has agreed to perform a commercially useful function in the work of the contract item(s) listed above and to execute a contract with the prime contractor. The undersigned further understand that no changes to this statement may be made without prior approval from the Champaign-Urbana Mass Transit District and that complete and accurate information regarding actual work performed on this project and the payment therefore must be provided to the **Champaign-Urbana Mass Transit District** .

---

Prime Contractor Signature

---

**Title**

---

**Date**

---

**Contact Person**

---

**Phone**

---

**Firm Name**

---

**Address**

---



---

DBE Firm Signature

---

**Title**

---

**Date**

---

**Contact Person**

---

**Phone**

---

**Firm Name** Company B

---

**Address**

---



# EXAMPLE OF COMPLETED FORM

## DBE Participation Statement

<b>Prime Contractor:</b> <span style="color: red;">Company A</span>	<b>Bid Date:</b> <span style="color: red;">07/16/2019</span>
<b>Job Location:</b>	<small>Street</small> Champaign-Urbana MTD    803 E University Ave.
	<small>City</small> Urbana
	<small>County</small> Champaign
<b>Job Description:</b>	Vehicle Lift Replacement

### 1. Instructions

This form must be completed for each disadvantaged business participating in the Utilization Plan. This form shall be submitted in accordance with the special provision and will be attached to the Utilization Plan form. If additional space is needed, complete an additional form for the firm.

### 2. Work

Item	Description of Work	Quantity	Unit Price	Total
	Equipment Supply	10	\$1.00	\$10.00
<b>Total</b>				<b>\$10.00</b>

### 3. Partial Payment Items

For any of the above items which are partial pay items, specifically describe the work and subcontract dollar amount below.

### 4. Commitment

The undersigned certify that the information included herein is true and correct, and that the DBE firm listed below has agreed to perform a commercially useful function in the work of the contract item(s) listed above and to execute a contract with the prime contractor. The undersigned further understand that no changes to this statement may be made without prior approval from the Champaign-Urbana Mass Transit District and that complete and accurate information regarding actual work performed on this project and the payment therefore must be provided to the **Champaign-Urbana Mass Transit District** .

---

Prime Contractor Signature

---

**Title**

---

**Date**

---

**Contact Person**

---

**Phone**

---

**Firm Name**

---

**Address**

---



---

DBE Firm Signature

---

**Title**

---

**Date**

---

**Contact Person**

---

**Phone**

---

**Firm Name** Company C

---

**Address**

---

# EXAMPLE OF COMPLETED FORM

## DBE Utilization Plan

### 1. Policy

It is public policy that disadvantageded businesses as defined in [49 CFR Part 26](#) and the Special Provision shall have the maximum opportunity to participate in the performance of contracts financed in whole or in part with Federal or State funds.

Consequently, the requirements of 49 CFR Part 26 apply to this contract.

### 2. Obligation

The contractor agrees to ensure that disadvantageded businesses as defined in 49 CFR Part 26 and the Special Provision have the maximum opportunity to participate in the performance of contracts or subcontracts financed in whole or in part with Federal or State funds. The contractor shall take all necessary and reasonable steps in accordance with 49 CFR Part 26 and the Special Provision to ensure that said businesses have the maximum opportunity to compete for and perform under this contract. The contractor shall not discriminate on the basis of race, color, national origin, or sex in the award and performance of contracts. Contractor to verify that all DBEs must be on the Illinois Unified Certification DBE Directory prior to or at bidding.

### 3. Project and Bid Identification

Complete the following information concerning the project bid.

<b>Prime Contractor:</b> <span style="color: red;">Company A</span>		<b>Bid Due Date:</b> <span style="color: red;">07/16/2019</span>	
<b>Job Location:</b> Champaign-Urbana MTD	<b>Street</b> 1101 E University Ave.	<b>City</b> Urbana	<b>County</b> Champaign
<b>Job Description:</b> Transit System Analysis			
<b>Total Bid Amount:</b> <span style="float: right;">\$ <span style="color: red;">100.00</span> -</span>	<b>Contract DBE Goal:</b>		<b>Dollar Amount</b>
	<b>Percentage</b> 5.45%	<b>Dollar Amount</b> \$ <span style="color: red;">5.45</span> -	

### 4. Assurance

I, acting in my capacity as an officer of the undersigned bidder (or bidders if joint venture), hereby assure **Champaign Urbana Mass Transit District** that on this project, my company: (check one)

- Meets or exceeds contract award goals and has provided documented participation as follows:
  - Disadvantaged Business Participation at 10 %
  - Attached is the signed participation statement (Form 2025), required by the Special Provision evidencing availability and use of each business participating in the plan and assuring that each business will perform a commercially useful function in the work of the contract.
  
- Failed to meet contract award goals and has included good faith effort documentation to meet the goals and that my company has provided participation as follows:
  - Disadvantaged Business Participation at                     %
  - The contract goals should be accordingly modified or waived. Attached is all information required by the Special Provision in support of this request including good faith effort.
  - Attached is the signed participation statement (Form 2025), required by the Special Provision evidencing availability and use of each business participating in the plan and assuring that each business will perform a commercially useful function in the work of the contract.

**Company** Company A

**By** John Doe

**Title** Chief Executive Officer

**Date** 3/14/2019



114 WEST MAIN STREET  
URBANA, ILLINOIS 61801

T / 217 328 1391  
F / 217 328 1401

## MEETING ATTENDANCE RECORD

**PROJECT:** CU-MTD  
Lift Replacement

**FILE NO.:** 1825

**MEETING DESCRIPTION:** Pre-Bid Meeting

**DATE:** 07/09/2019 **TIME:** 1:30 PM

**PLACE:** CU-MTD - 803 East University, Urbana, IL- 61802

Attendant: Name & Title	Representing
1. <u>CHARIS EDKINS PROJECT MGR</u>	<u>IL OIL MKTG</u>
2. <u>Brad Rodgers Sales rep</u>	<u>IL OIL MKTG</u>
3. <u>Eric Brogan</u>	<u>MTD</u>
4. <u>SCOT WACHTER</u>	<u>IGW</u>
5. <u>Kirk Kirkland</u>	<u>MTD</u>
6. <u>SHARADA PANDITI</u>	<u>IGW</u>
7. _____	_____
8. _____	_____
9. _____	_____
10. _____	_____
11. _____	_____
12. _____	_____
13. _____	_____
14. _____	_____
15. _____	_____
16. _____	_____
17. _____	_____
18. _____	_____

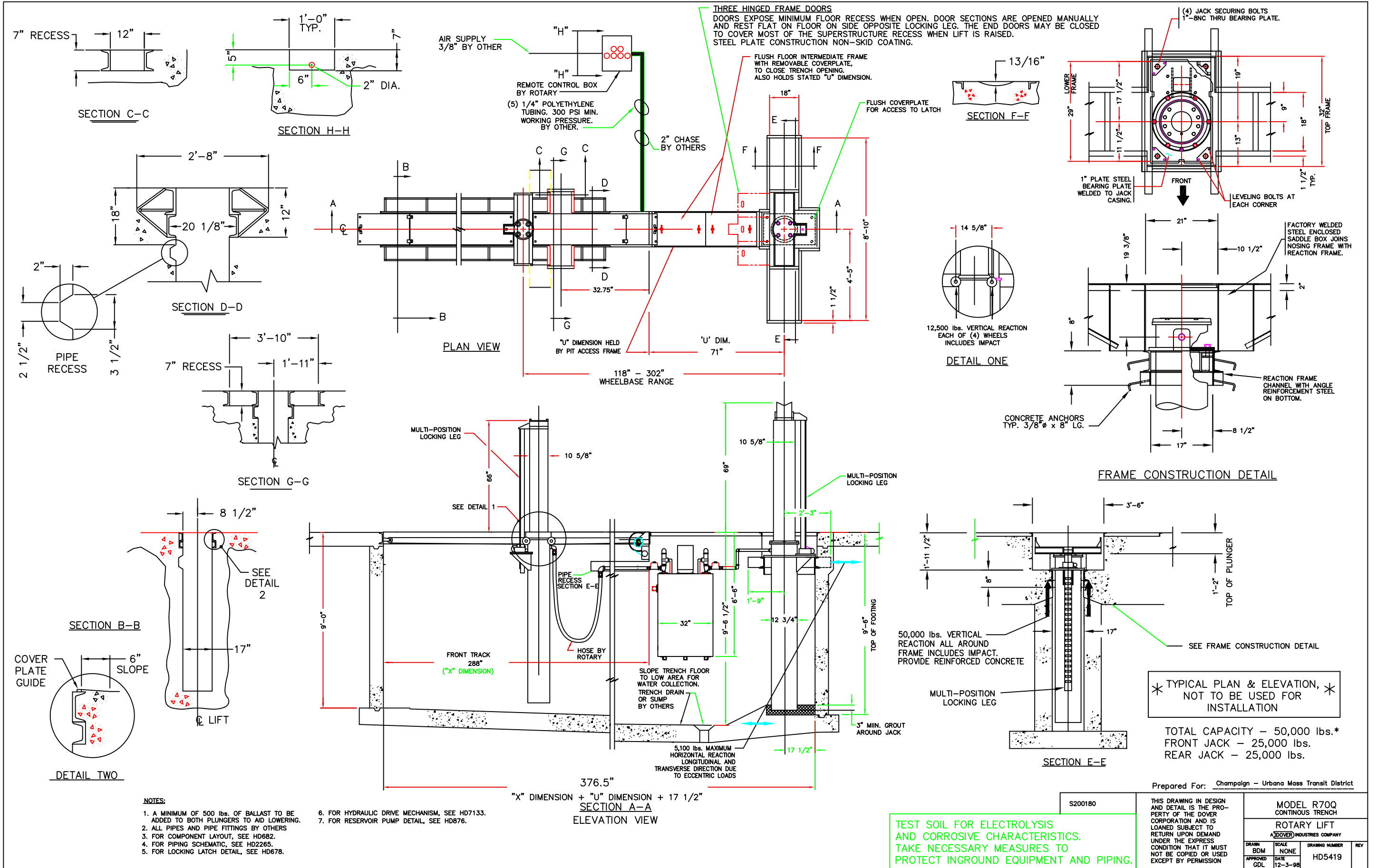

FOR REFERENCE ONLY – NOT FOR CONSTRUCTION

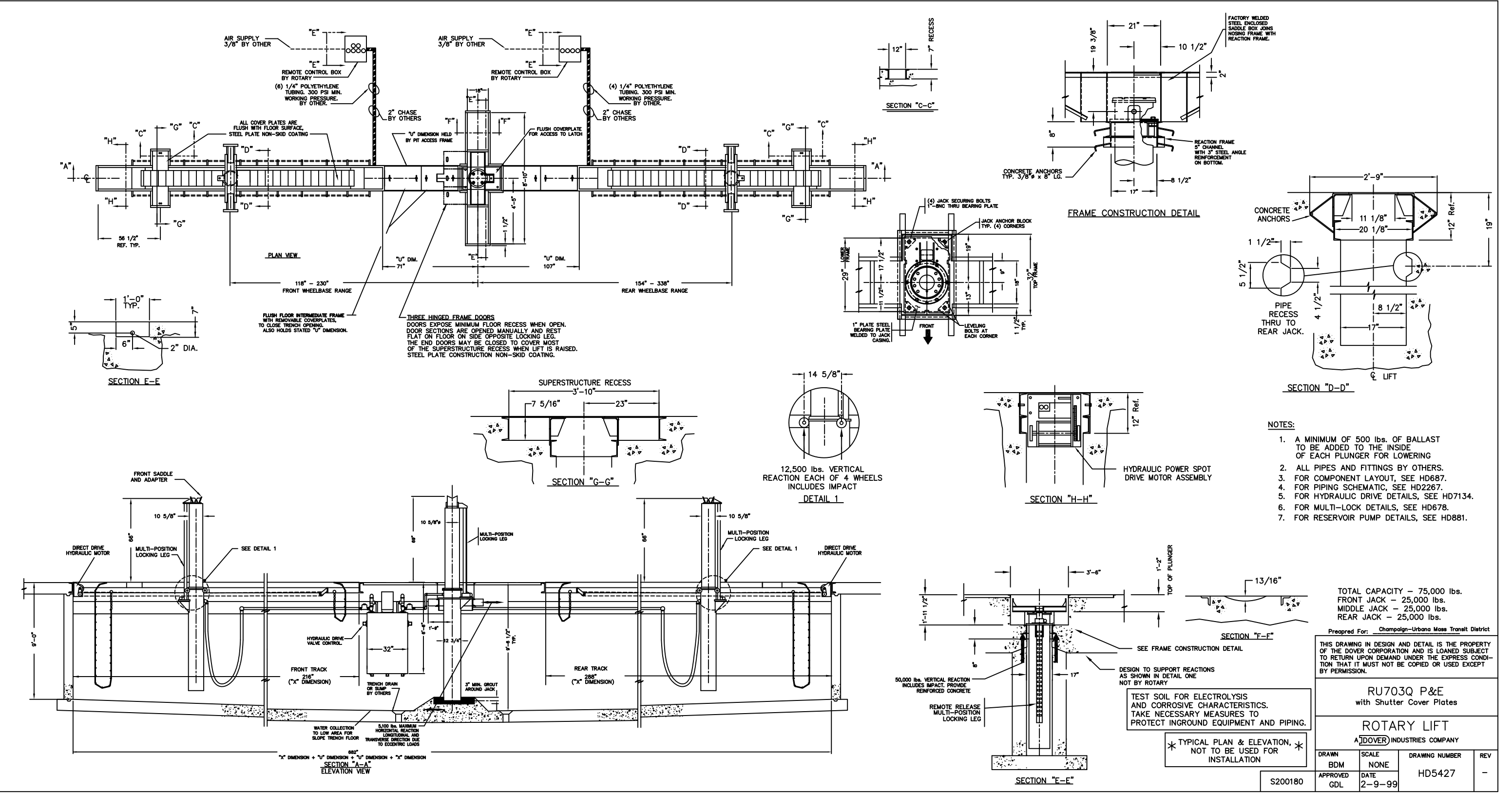

FOR REFERENCE ONLY – NOT FOR CONSTRUCTION

**BIDDING & CONTRACT REQUIREMENTS**

Document 009002 – Addendum No. 02

DATE: July 12, 2019

The MTD Board  
1101 E. University Ave  
Urbana, Illinois 61802

IGW Architecture  
114 West Main Street / Urbana, Illinois 61801  
Tel 217-328-1391 Fax 217-328-1401

TO: PROSPECTIVE BIDDERS

SUBJECT: ADDENDUM NO. 2 TO THE BIDDING DOCUMENTS FOR

CUMTD – Lift Replacement  
803 E. University Ave., Urbana, IL, 61802

This addendum forms a part of the bidding and contract documents and modifies the original bidding documents, dated June 17, 2019. Acknowledge receipt of this addendum in space provided on Bid Form. FAILURE TO DO SO MAY SUBJECT BIDDER TO DISQUALIFICATION.

**PROJECT MANUAL**

1. Section 00 11 13 – Advertisement for Bids
  - A. Change Bid Date to Tuesday, July 30, 2019 at 1:30 pm, same location.
2. Section 01 10 00 – Summary
  - A. Change Paragraph 1.5, B, C and D as follows:  
SCHEDULE AND PHASED CONSTRUCTION.
  - B. Receipt of Bids - July 30, 2019.
  - C. Anticipated Notice of Award after Board approval – August 29th, 2019.
  - D. Start of Construction – After September 2<sup>nd</sup>, 2019.

**DRAWINGS:**

None.

Bids are due on **Tuesday, July 30, 2019** at 1:30 P.M. prevailing time.

Bids are due at: CUMTD-Headquarters,  
1101 E. University Ave  
Urbana, IL, 61802

Attachments:

Specification Sections: None  
Drawings: None

Respectfully submitted,  
IGW Architecture

This addendum consists of 2 pages.